

# WOOD LOG BOILERS

17 – 110 kW

**HARGASSNER**  
BIOMASS HEATING TECHNOLOGY



[hargassner.com](http://hargassner.com)

# Table of contents



- 4 Good reasons for heating using wood logs
- 6 Overview of all wood log boilers
- 8 Smart-HV 17 – 23
- 10 Smart-HV advantages
- 12 Neo-HV 20 – 60
- 14 Neo-HV advantages
- 16 Neo-HV Premium
- 18 Wood log & pellet combi boiler
- 20 Neo-MHV 30 – 45
- 22 MV 55 – 110
- 24 Neo-MHV + MV advantages
- 26 Smart home & control unit
- 28 Boiler operation and touch display
- 30 Accumulator systems
- 32 Heating accessories
- 34 Technical data



Left to right: Philipp Aschenwald, Jonas Geiner & Daniela Iraschko-Stolz

## Winter sports are our passion!

The fire burns in our eyes. Not just because we build sustainable biomass heating systems, but also because we are passionate sports fans. While it was once Anton Hargassner sr. himself who daringly pushed himself off the ski jump beam at a young age, he later kindled this fire for sport in Markus and Anton jr. Hargassner as well. This passion still burns in the Hargassner family today and the values of sport therefore also actively shape Hargassner's corporate culture. The "Hargassner Sport Family" unites this enthusiasm for sports, from youngsters to professionals, and shares it with the international fan community.

If you would like to be kept informed and experience first-hand everything that is going on in the world of the "Hargassner Sport Family", please follow them on their Facebook & Instagram social media channels. **#hargassnerfamily**  

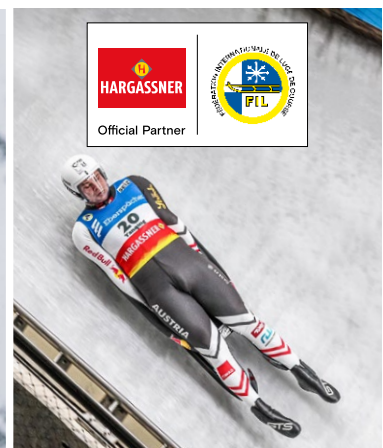
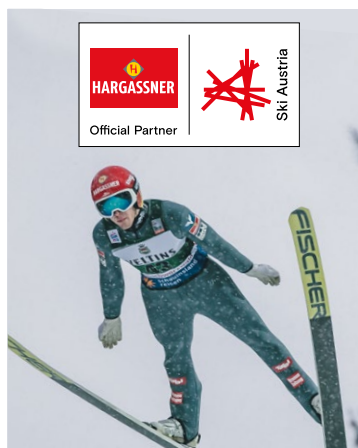



## Our corporate values are characterised by **harmony between nature and satisfied customers**

Hargassner. Since 1984, as a pioneer in automated biomass heating systems, we have endeavoured to stand by our customers as a reliable partner – with trustworthiness from Innviertel. We have now grown into an internationally successful company with a pronounced spirit of innovation.

- ✓ Over **39 years of experience**
- ✓ **170,000 customers** worldwide
- ✓ **75,000 m<sup>2</sup> company floor space**
- ✓ More than **1,200 employees** at several locations
- ✓ **Export to 43 countries**
- ✓ **International awards**



Managing directors (left to right)  
Markus & Anton jr. Hargassner



# Heating with Wood log

## Advantages

- ✓ **Lower costs than oil or gas**
- ✓ **Crisis-resistant**, because locally sourced
- ✓ **Short transportation**
- ✓ **Convenient** thanks to long combustion times
- ✓ **Accumulator storage tank combination**
- ✓ **Value creation process** remains in the region
- ✓ **Efficient & energy saving**

**Environmentally friendly.** Wood logs are CO<sub>2</sub>-neutral. In general, the cleaner combustion results in a very high CO<sub>2</sub> reduction compared to heating oil.

**Local.** Using wood logs offers a future-proof market for local companies and secure jobs in the region.

**Efficient.** The combination of low fuel costs and highly efficient boiler technology makes wood logs attractive not only for forest owners.

**Independent.** There is a high degree of independence due to the supply from domestic forests. Control over the production process is entirely domestic.



## Facts

**1/2 metre:** EN ISO 17225-5:2014, class A1-B, L50

**1 metre:** EN ISO 17225-5: 2014 class A1-B, L100

**Size:** Ø 10 cm on average for 1/2 m

**Water content:** < 20%

**Calorific value:** 4.4 kWh/kg



Timber harvesting & log splitting with machine support



### Energy prices per year\*

Comparing the costs of individual fuels down into cents/kWh reveals an astonishing picture:

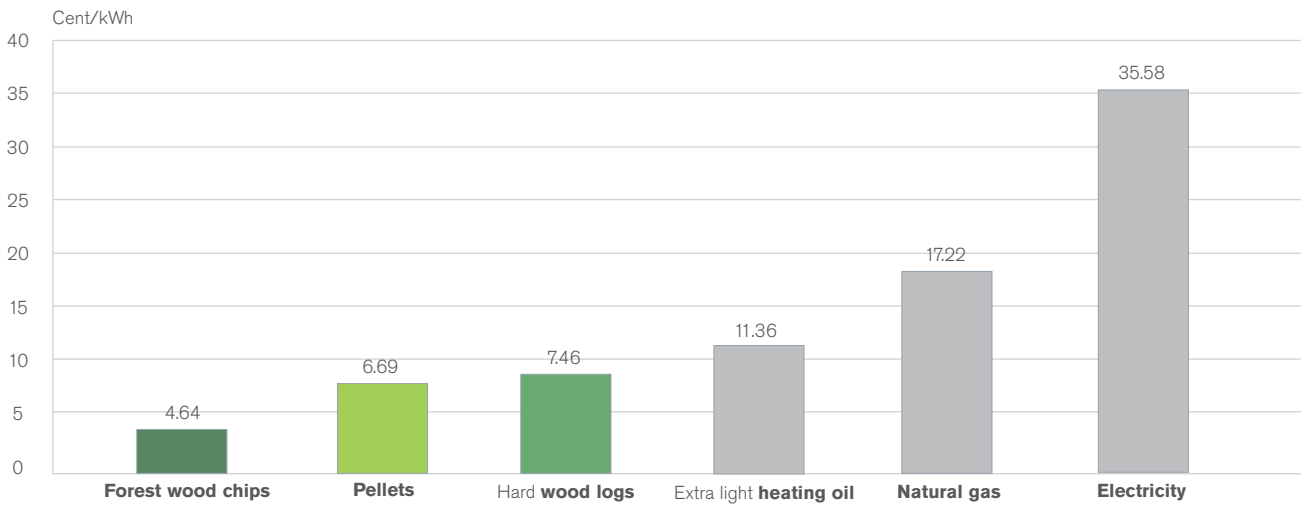

\* Basis: Reference value is the calorific value 15,000 kWh gas, 3500 kWh electricity excluding new customers, 1000 litres heating oil, 1000 kg pellets, 1000 kg wood chips, 1000 kg wood chips (flat rate) for 1,000 litres of extra light heating oil free domicile (based on a delivery quantity of 3,000 litres; Source: proPellets, Landwirtschaftskammer Österreich, E-Control, IWQ, Österreichische Biomasseverband; Last updated: 24 April 2023)

### Course of the production of wood logs

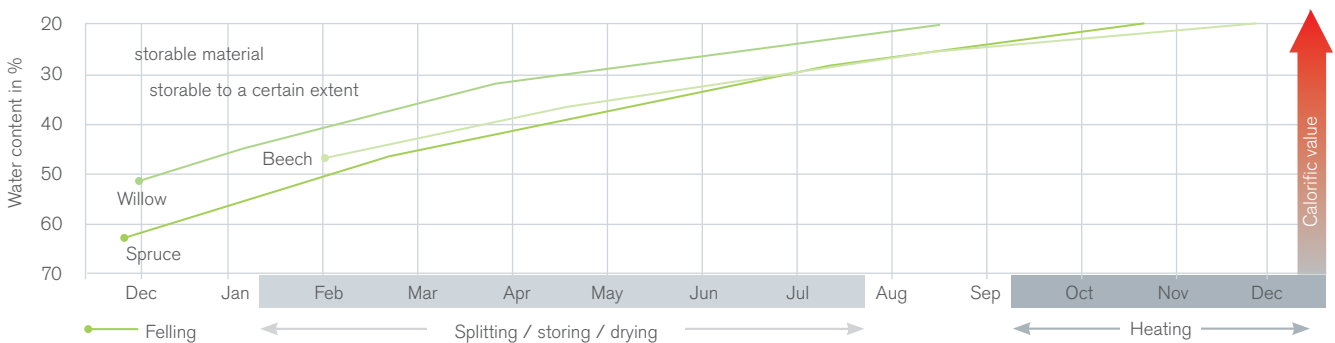

# The variety of our wood log boilers

## SMART HV

17 – 23 kW

½ m wood log gasifier

**Perfect for:**

- Detached houses
- Weekend homes

For details, see p. 8



## NEO HV

20 – 60 kW

½ m wood log gasifier

**Perfect for:**

- Detached houses
- Multi-dwelling units
- Agriculture & forestry

For details, see p. 12



### **Biomass heating technology at its best**

Products from Hargassner combine the highest quality, expertise and decades of proven technology. As a biomass pioneer, Hargassner researches and develops the future of heating with a keen sense of the environment. These innovations make the boilers some of the best biomass heating solutions available in the world today. Lowest emissions at the highest efficiencies, maximum convenience and long lifetime characterise the "Hargassner" brand. Research, quality control



## NEO MHV

30 – 45 kW

**½ & 1 m wood log gasifier**

**Perfect for:**

- Detached houses
- Multi-dwelling units
- Agriculture & forestry

For details, see p. 20



## MV

55 – 110 kW

**1 m wood log gasifier**

**Perfect for:**

- Agriculture & forestry
- Business

For details, see p. 22



and the focus on customer satisfaction therefore characterise the daily tasks to a high degree. Many customers are already benefiting from this success story. A capacity of more than 30,000 boilers produced per year and over 170,000 satisfied buyers worldwide are proof of the top level of Hargassner heating technology.

**Discover the wide world of Hargassner wood log boilers on the following pages.**



Our Smart-HK boiler series have been awarded the EnergieGenie (energy genius) innovation prize. You can find more information about our awards and prizes on our website [hargassner.com](http://hargassner.com)





# SMART HV

17 – 23 kW

The Smart-HV impresses with its compact size, its functionality and of course its excellent price-performance ratio. The ingenious gasification technology comes from its exclusive brother - the Neo-HV.

- ✓ **Minimum space requirements with ½ m logs**
- ✓ **Sophisticated wood gasification technology**
- ✓ **Touch display** for convenient adjustment
- ✓ **Smoke-free refilling**
- ✓ **Easy filling**
- ✓ **Manual cleaning**
- ✓ **Convenient and quick ignition**

## Application areas

-  Detached houses
-  Weekend homes



Also available as a wood log pellet combi boiler!  
For details, see p. 18

- + — H x W x D = 1,290 x 655 x 970 mm
- + — Energy efficiency class **A+**
- + — Efficiency of up to 94 %
- + — 5-year warranty



# Smart heating at the lowest price

Smart-HV 17 – 23

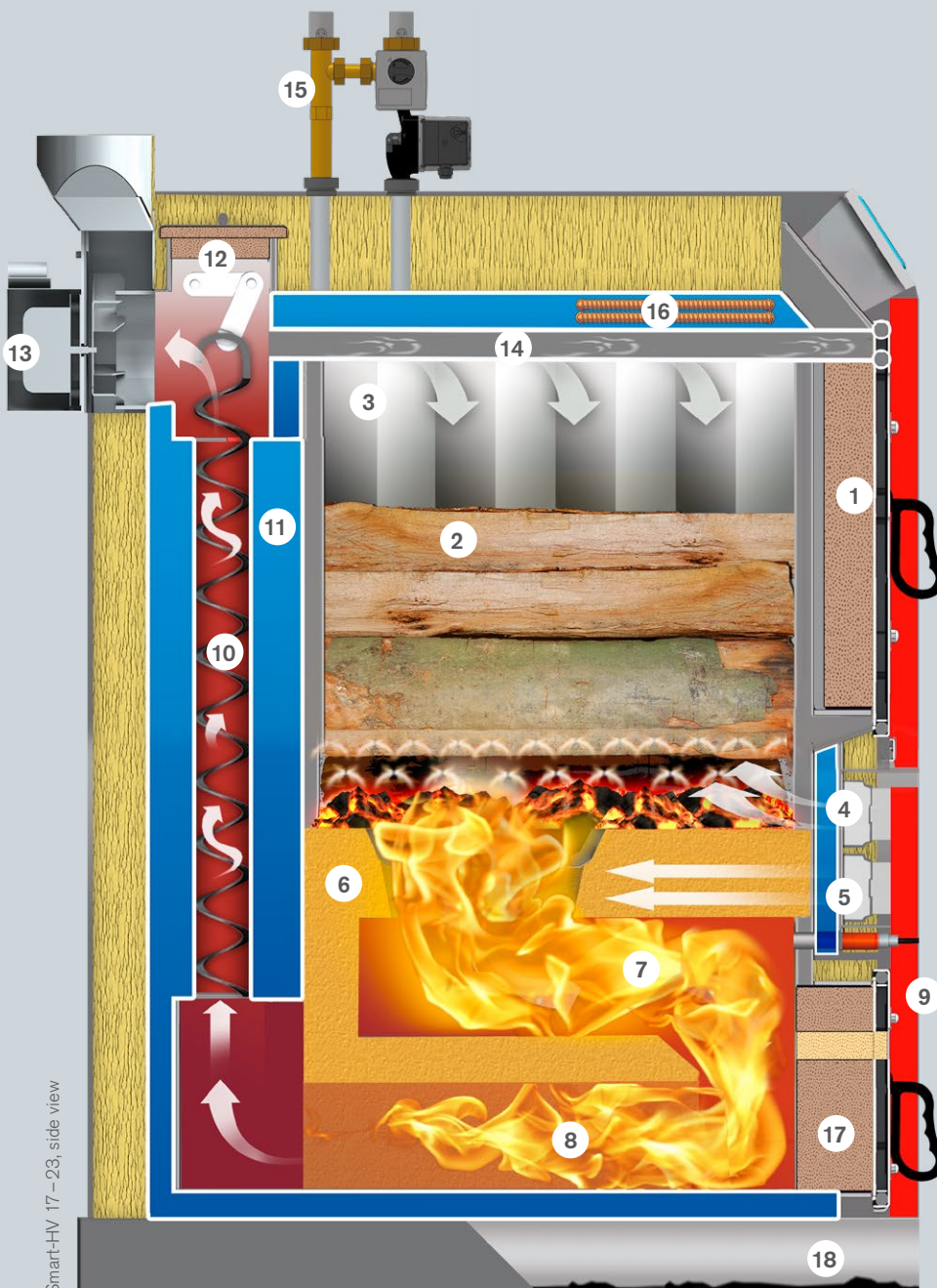

- 1 Large filling door (can have hinges on right or left)
- 2 Filling chamber for ½ m logs (up to 53 cm)
- 3 Combustion chamber lining – prevents tar formation
- 4 Primary air servomotor
- 5 Secondary air servomotor
- 6 High-quality, massive refractory-lined combustion chamber
- 7 High-temperature burnout zone
- 8 Ash separation zone
- 9 Lambda sensor
- 10 Turbulators
- 11 Heat exchanger
- 12 Manual boiler cleaning system
- 13 Exhaust fan
- 14 Top smoulder gas ventilation
- 15 Optional back-end protection
- 16 Cooling coil for thermal safety circuit
- 17 Cleaning door
- 18 Ash pan

Smart-HV 17 – 23, side view



# SMART HV

The future of heating



### Fully refractory-lined high-performance combustion chamber for optimum post-combustion

The refractory combustion chamber's special **storage effect** guarantees high combustion temperatures (even for partial load), and ensures convenient self-ignition even with long refilling intervals.

It doesn't matter which fuel type you use – softwood or hardwood logs, or briquettes – the control unit uses the lambda sensor to detect the relevant calorific value and sets the primary and secondary air with separate servomotors. Your heating system is always working with the required output at the best combustion values.

### Speed controlled EC exhaust fan

Depending on the heat demand, the control unit regulates the speed of the exhaust fan. This concept ensures ideal combustion with minimal flue gas temperatures and therefore maximum efficiency. The EC motor is extremely energy-efficient and thus saves operating costs.

### Manual cleaning of the heat exchanger

Simply move the external cleaning lever back and forth several times and the heat exchangers are free of deposits once again. The ash can then be conveniently pushed into the ash pan at appropriate intervals using the cleaning tools supplied. The cleaning lever can be mounted on the right and left of the boiler, depending on the installation situation.





### **Lambda Touchtronic control unit**

This unique boiler control with touch-screen operation for increased ease of use controls the entire combustion process. Via an additional module, all the heat circuits can be controlled according to the outdoor temperature and the hot water tank can be connected to a differential controller.

### **Easy to clean**

All maintenance parts are accessible from the front side. Easy ash removal from the front into the ash tray below.

### **Back-end-protection / heat distribution**

The return temperature is kept high by the return mixer group. The heat is simultaneously sent to the accumulator tank.



### **Easy refilling**

The large door ensures easy refilling of the very large filling chamber (102 l). The logs can be up to 53 cm long. An especially optimised lining in the filling chamber ensures efficient combustion without tar formation. A smoulder gas channel at the top sucks out the residual smoulder gases when the chamber is being filled. Clean and efficient!





## NEO HV

20 – 60 kW

All technical details of the Neo-HV are optimised for optimum ease of operation and maintenance. A separate premium package increases the Hargassner operating comfort to a maximum. An all-round perfect gasifier for your own wood log boiler.

- ✓ **Filling chamber size for ½ m logs**
- ✓ **State-of-the-art combustion control**
- ✓ Automatic **boiler cleaning system**
- ✓ **Touch display** for convenient adjustment
- ✓ **Filling chamber lighting** as standard
- ✓ Optional **automatic ignition**
- ✓ Optional **premium version**

## Application areas

-  Detached houses
-  Multi-dwelling units
-  Agriculture & forestry



Also available as a wood log pellet combi boiler!  
For details, see p. 18

- ⊕ — H x W x D = 1,665 x 660 x 1,310 mm (Neo-HV 20 – 30)
- ⊕ — H x W x D = 1,730 x 740 x 1,370 mm (Neo-HV 40 – 60)
- ⊕ — Energy efficiency class **A+**
- ⊕ — Efficiency of up to 93.7 %
- ⊕ — 5-year warranty

# Innovative gasifier technology

Neo-HV 20 – 60

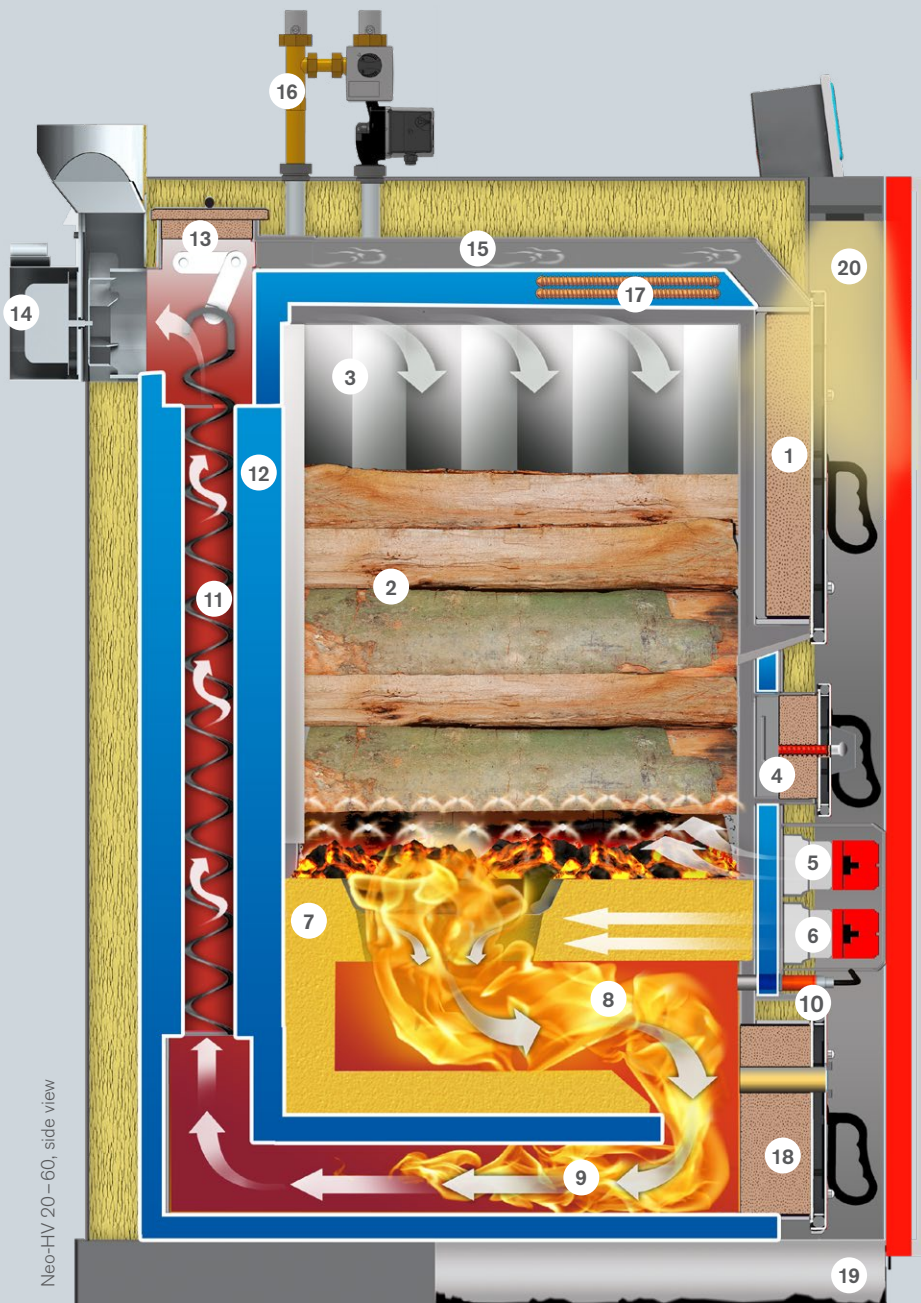

Neo-HV 20 – 60, side view

- 1 Large filling door
- 2 Large filling chamber for ½ m logs (up to 60cm)
- 3 Combustion chamber lining – prevents tar formation
- 4 Heat-up door with automatic ignition (optional)
- 5 Primary air servomotor
- 6 Secondary air servomotor
- 7 High-quality, massive refractory-lined combustion chamber
- 8 High-temperature burnout zone
- 9 Ash separation zone
- 10 Lambda sensor
- 11 Turbulators
- 12 Heat exchanger
- 13 Automatic boiler cleaning system
- 14 Exhaust fan
- 15 Top smoulder gas ventilation
- 16 Optional back-end protection
- 17 Cooling coil for thermal safety circuit
- 18 Cleaning door
- 19 Ash pan
- 20 Filling chamber lighting as standard



# NEO HV

## The future of heating

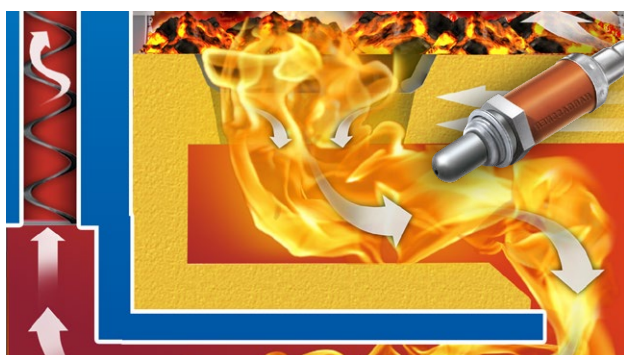

### Fully refractory-lined high-performance combustion chamber for optimum post-combustion

The refractory combustion chamber's special **storage effect** guarantees high combustion temperatures (even for partial load), and ensures convenient self-ignition even with long refilling intervals.

It doesn't matter which fuel type is used – softwood or hardwood logs, or briquettes – the control unit uses the lambda sensor to detect the relevant calorific value and sets the optimum primary and secondary air with two separate servomotors. The heating system is always working with the **ideal output** at the best combustion values.

### Speed controlled EC exhaust fan

The Lambda Touchtronic will control the speed of the exhaust fan according to the required output. This ensures combustion with minimal flue gas temperatures and therefore maximum efficiency. The EC motor is extremely energy-efficient and thus saves operating costs. There is also a rotary flue pipe connector available as an accessory which, if required, can be positioned at the top or on the left or right.



### Automatic heat exchanger cleaning

Gone are the days of manual heat exchanger cleaning. The automatic heat exchanger cleaning system takes care of everything. This guarantees continuously high efficiency levels and reduces the amount of cleaning you have to do.

solid

high res

4269814



**Lambda Touchtronic control unit**

This unique boiler control with touch-screen operation for increased ease of use controls the entire combustion process. In addition, all the heat circuits can be controlled according to the outdoor temperature and the hot water tank can be connected to a differential controller.



**Filling chamber lighting**

This enables you to conveniently fill or easily clean the filling chamber.

**Back-end protection / heat distribution**

The return temperature is kept high by a return mixer group attached to the boiler itself and the heat is simultaneously sent to the heat circuits and/or the accumulator tanks.



**Easy refilling**

The large door ensures easy refilling of the very large filling chamber (166 / 222 l). The logs can be up to 60 cm long.

**Clean combustion**

The optimised lining in the filling chamber ensures efficient combustion without tar formation. A smoulder gas channel at the top sucks out the residual smoulder gases when the chamber is being filled.

**Easy to clean**

All components are accessible from the front side: Easy ash removal from the front into the ash tray below.



Highest demands  
**for heating**  
**with wood logs**



# The high-end model among the wood gasifiers

## Neo-HV Premium 20 – 60

The "Neo-HV Premium" range of wood log boilers is the right choice for anyone looking for maximum comfort and powerful, original heating performance.

The technological sophistication paired with the durable quality of the Neo-HV results in heating with wood logs at the highest level for the best price-performance ratio – in other words, premium.



### NEO HV PREMIUM

#### **Stainless steel filling chamber lining**

The high-quality filling chamber lining ensures a long lifetime for the Neo-HV Premium.



#### **Automatic ceramic ignition**

It increases convenience and guarantees the heat supply.



#### **Convenience ash pan**

The special cover and integrated carrying handle allow you to dispose of the ashes conveniently and dust-free.





## COMBI BOILER

### Combines the best of wood logs & pellets

Hargassner has decades of experience in biomass heating technology. A know-how advantage that leads to particularly sophisticated technology when combining wood logs and pellets. The arrangement with two separate heat exchangers achieves the highest system efficiencies. At the same time, the advantages – the comfort of pellets and the low cost of logs – are ideally combined.

- ✓ **Highest controllability and maximum efficiency**
- ✓ **Fuel supply security** for the future
- ✓ **Two separate, efficient heat exchanger systems**  
for just one chimney
- ✓ **Fully automatic changeover**

### Application areas

- 🏠 Detached houses
- 🏠 Semi-detached houses



Combination of wood log boiler Neo-HV & pellet boiler Nano-PK

- + Energy efficiency class **A+**
- + Efficiency of up to 96%
- + 5-year warranty
- + More information in the combined brochure

## NEO HV + NANO PK 20 – 60 kW    6 – 32 kW

### The allrounder for maximum comfort

This combi option is impressive because it consists of an automatic wood log boiler boasting a large filling chamber and a pellet boiler with an automatic heat exchanger cleaning system and an innovative fuel extraction system. The wood log boiler is ignited automatically when the accumulator can no longer cover the heat demand. If the wood log boiler has not been filled, the system will automatically switch to the pellet boiler. The pellets are suctioned directly out of their storage room and into the hopper.



## NEO HV + SMART PK 20 – 60 kW    17 – 32 kW

### For wood log boiler operator with sporadic pellet operation

This combination consisting of an automatic wood log boiler with a large filling chamber and a pellet boiler with manual filling and long filling intervals of up to a week guarantees maximum heating convenience. The wood log boiler is ignited automatically when the accumulator can no longer cover the heat demand. If the wood log boiler is empty, the system will automatically switch to pellets. This combi option can run for up to ten days without being refilled.



## SMART HV + NANO PK 17 – 23 kW    6 – 32 kW

### For the pellet boiler operator with occasional wood log operation

This option consisting of a pellet boiler with an automatic heat exchanger cleaning system and a fuel extraction system in conjunction with a Smart-HV wood log boiler is distinguished by its small, compact design. The pellets are automatically suctioned out of their storage room and into the hopper. This combi option can run completely automatically and is suitable for occasional wood log operation.



## SMART HV + SMART PK 17 – 23 kW    17 – 32 kW

### The combi boiler for the economical customer

This very cost-efficient Hargassner solution consists of a wood log boiler and a pellet boiler that are both filled manually. The heat exchanger is also cleaned manually. If the wood log boiler has not been filled, the system will automatically switch to pellets. This combi option can run for up to ten days without being refilled. Top price-performance ratio.





## NEO MHV



### 30 – 45 kW

The Neo-MHV gives wood log boiler operators with higher heating requirements the freedom to choose: with two log lengths, there are twice as many options for reliable heat. Despite its extremely large filling chamber, it is still a real space saver.

- ✓ **300 l filling chamber for ½ m & 1 m logs**
- ✓ Integrated **back-end protection**
- ✓ **Minimum space requirements**
- ✓ **Easy to install**



## Application areas

-  Detached houses
-  Multi-dwelling units
-  Agriculture & forestry

- ⊕ — H x W x D = 1,770 x 850 x 1,435 mm
- ⊕ — Energy efficiency class **A+**
- ⊕ — Efficiency of up to 91.4 %
- ⊕ — 5-year warranty

# The "big one" from Hargassner

## Neo-MHV 30–45

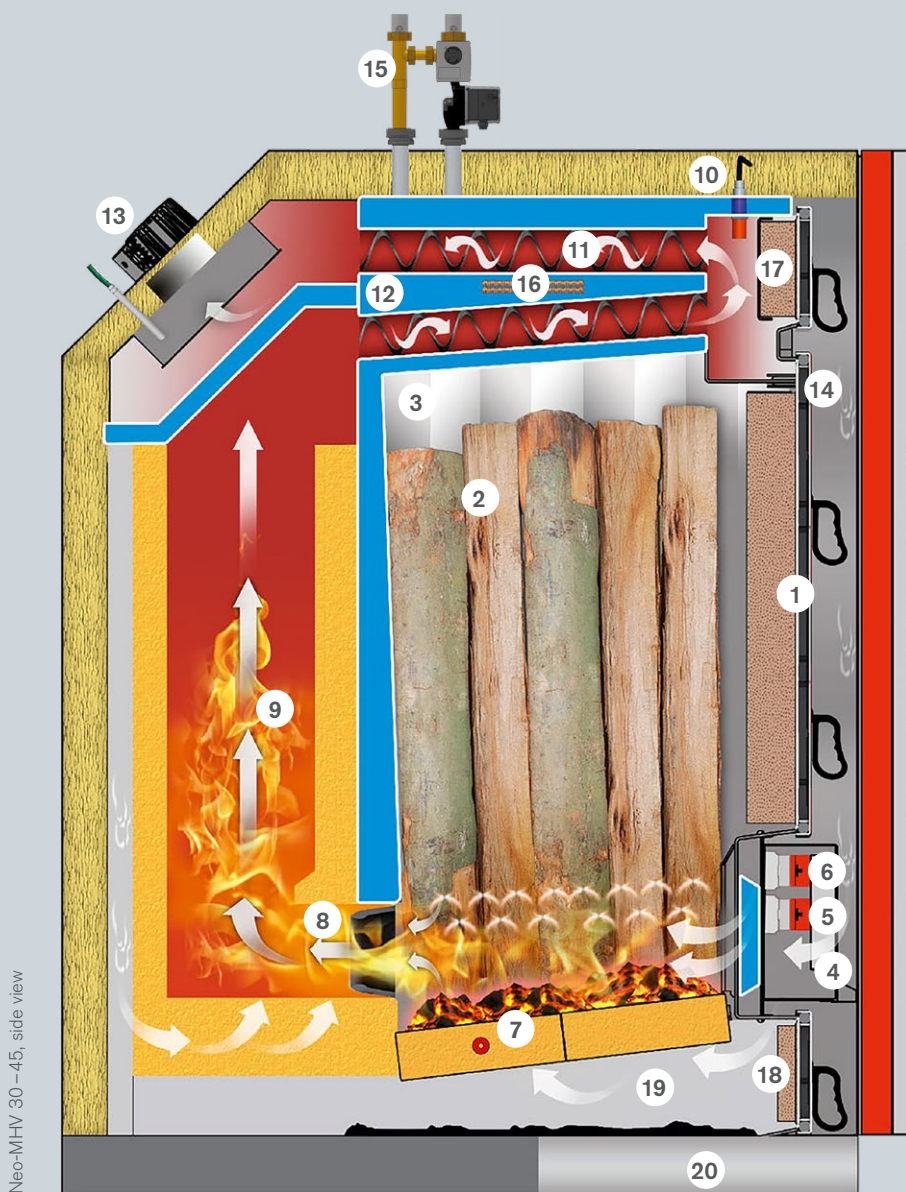

- 1 Large filling door
- 2 Filling chamber for ½ m and 1 m logs (up to 110 cm)
- 3 Combustion chamber lining – prevents tar formation
- 4 Speed-controlled pressure fan
- 5 Primary air servomotor
- 6 Secondary air servomotor
- 7 Automatic ignition
- 8 Gas-burning honeycomb
- 9 High-temperature burnout zone
- 10 Lambda sensor
- 11 Turbulators
- 12 Heat exchanger
- 13 Exhaust fan
- 14 Top smoulder gas ventilation
- 15 Back-end protection
- 16 Cooling coil for thermal safety circuit
- 17 Cleaning door for heat exchanger
- 18 Cleaning door
- 19 Ash chamber
- 20 Ash pan

Neo-MHV 30–45, side view



# MV

## 55 – 110 kW

The strong power package in the wood gasifiers powerfully converts the energy in the wood into the highest performance values. The MV for logs up to 110 cm long has thus secured a spot among the top sellers of Hargassner log boilers.

- ✓ **Filling chamber sizes of 450l (MV 55–80) or 720l (MV 90–110) for 1 m logs**
- ✓ **Back-end protection**  
included in scope of delivery
- ✓ **Unique automatic ignition**



## Application areas

 Agriculture & forestry

 Business

- ⊕ — H x W x D = 1,555 x 910 x 1,880 mm (MV 55 – 80)
- ⊕ — H x W x D = 1,820 x 1,000 x 1,910 mm (MV 90 – 110)
- ⊕ — Efficiency of up to 94.9%
- ⊕ — 5-year warranty

# Maximum combustion power

MV 55 – 110

- 1 Large filling door
- 2 Large filling chamber for 1 m logs (up to 110 cm)
- 3 Combustion chamber lining – prevents tar formation
- 4 Ash door
- 5 Primary air servomotor
- 6 Secondary air servomotor
- 7 Gas-burning honeycomb with injector nozzle
- 8 High-temperature burnout zone
- 9 Lambda sensor
- 10 Turbulators
- 11 Heat exchanger
- 12 Cleaning door for heat exchanger
- 13 Exhaust fan
- 14 Top smoulder gas ventilation
- 15 Back-end protection
- 16 Cooling coil for thermal safety circuit
- 17 Secondary air channel
- 18 Ash chamber
- 19 Ash pan

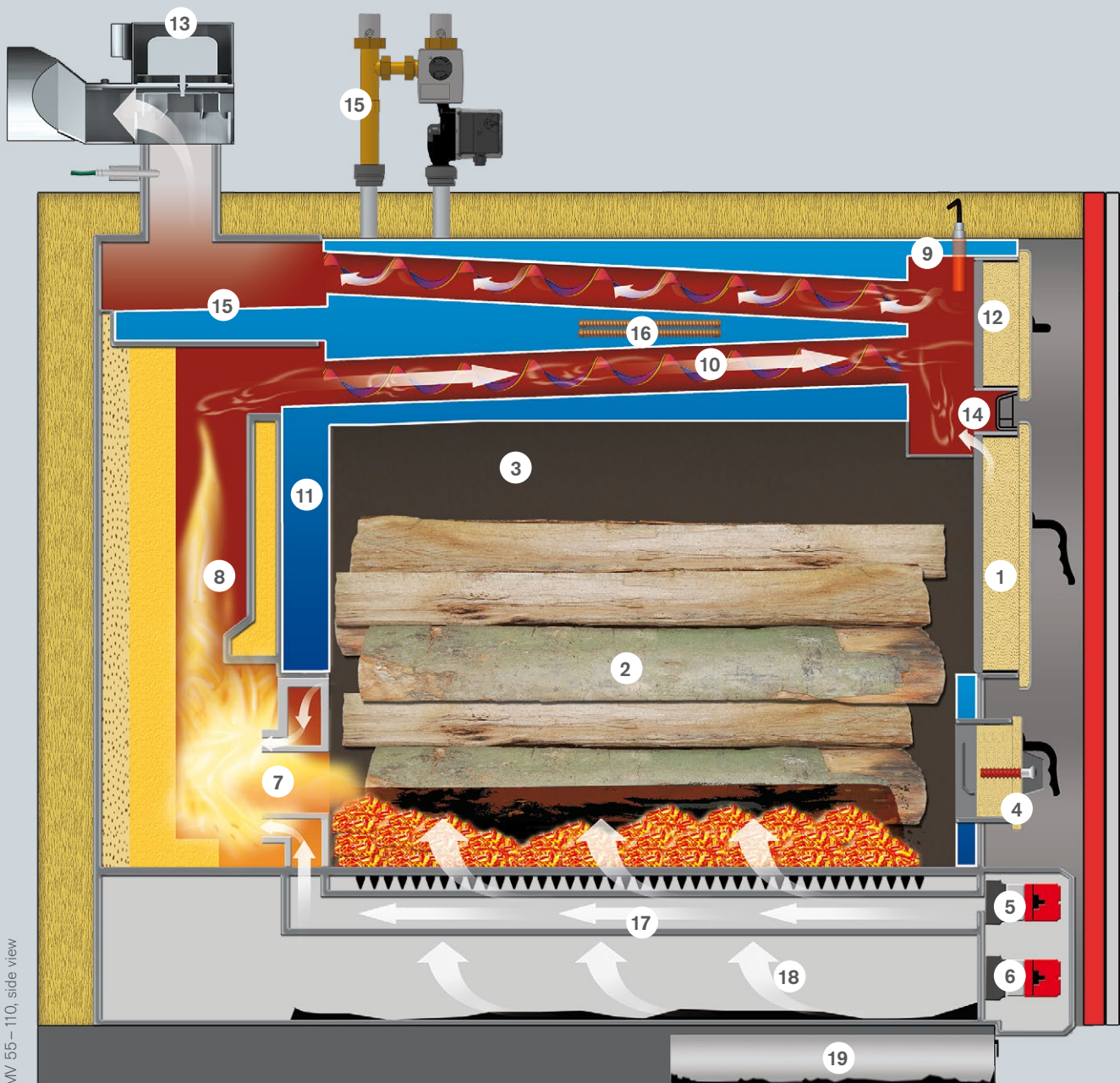

MV 55 – 110, side view

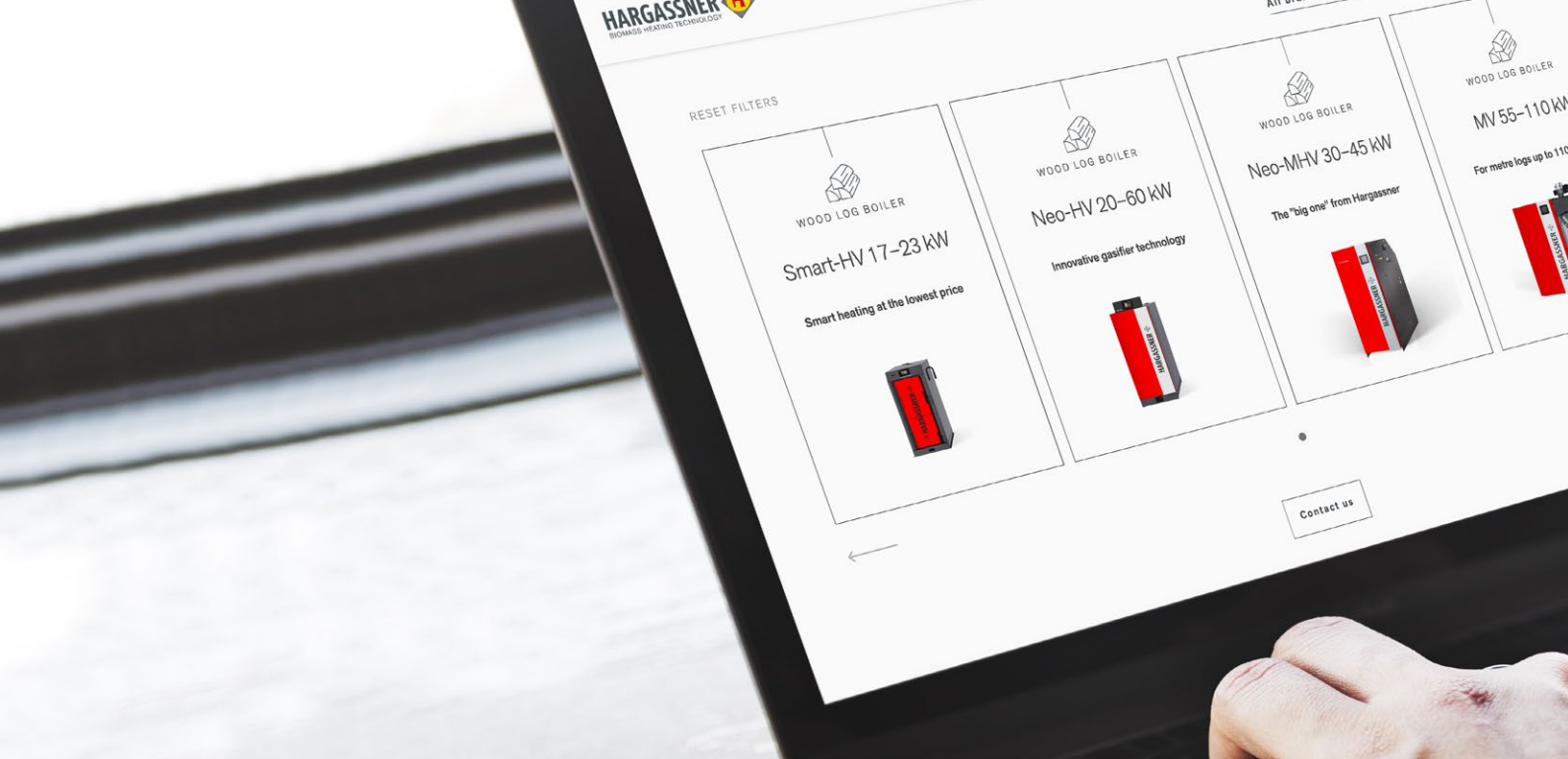

## NEO MHV and MV

### The future of heating



#### Fully refractory-lined high-performance combustion chamber for optimum post-combustion

The refractory combustion chamber's special **storage effect** guarantees high combustion temperatures (even for partial load).

It doesn't matter which fuel type you use – softwood or hardwood logs, or briquettes – the control unit uses the lambda sensor to detect the relevant calorific value and sets the primary and secondary air with separate servomotors. Your heating system is always working with the **ideal output** at the best combustion values.

#### Speed controlled EC exhaust fan

Depending on the heat demand, the control unit regulates the speed of the exhaust fan. This concept ensures optimum combustion with minimal flue gas temperatures and therefore maximum efficiency. The EC motor is extremely efficient and thus saves operating costs.



#### Excellent combustion

Via the gas-burning honeycomb with injector nozzles, the wood gases are mixed in a vortex with preheated, secondary combustion air. The wood gases thus burn perfectly in the high-temperature combustion chamber.



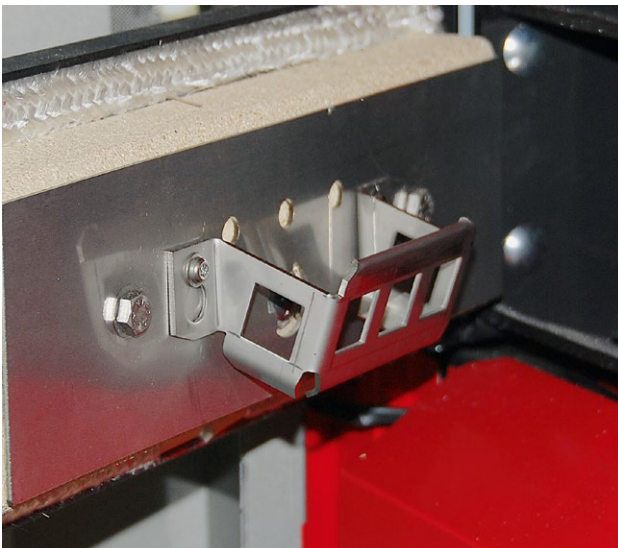

#### **Heat-up convenience through automatic ignition**

The heat-up door is equipped with an automatic ignition. The boiler is filled with logs and the heat-up door with a piece of paper. When heat is required, the boiler ignites automatically.

#### **Back-end protection / heat distribution**

The return temperature is kept high by the integrated return mixer group. The heat is simultaneously sent to the accumulator tank.



#### **Easy refilling**

The large door at the front ensures easy refilling of the very large filling chamber with half-metre or one-metre logs. A smoulder gas channel at the top sucks out the residual smoulder gases when the chamber is being filled. There is also an optional side shaft for the MV 55 to 110 types.

#### **Easy to clean**

Everything is accessible from the front. The boiler is easy and convenient to de-ash into the ash pan below.

# Anywhere, anytime

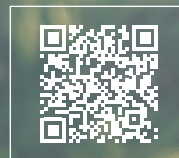

Hargassner app  
Click here to download  
for iOS!



Hargassner app  
Click here to download for  
Android!



Awarded  
1st place for the  
APP-AWARD 2022

# SMART HOME & BOILER ACCESSORIES

## Control accessories for every need

The Hargassner standard control covers the majority of the requirements in a modern house. However, if further heat circuits, solar collectors, etc. are to be connected, additional boards and remote controls are available. The right solution for every requirement: for more information, visit our homepage or contact your Hargassner installation company.



**Heat circuit module HKM:** This heat circuit module is used to extend heat and HWT circuits. It is integrated into the control unit of the entire system and controls up to two mixer-controlled heat circuits & one HWT circuit with DHW circulation pump. Additionally, an external heat circuit or an accumulator tank and other HKM's can be connected.



**Additional boards:** Hargassner offers a wide variety of additional boards for extending heat circuits, etc. **Additional board A/B** are used to add a heat circuit and a hot water tank to a heating system. **Additional board F** is used to control mixed district lines. If up to two additional sensor inputs are required, **additional board PF** is used. Furthermore, there is also **additional board S**, which acts as a differential controller for a solar system in single-circuit or double-circuit operation. Your specialist Hargassner dealer will be happy to explain all other additional boards and their exact use to you.



**Heat circuit controller HKR with touch:** The HKR is a weather-compensated outdoor temperature controller with touch control unit. The controller sends the heating system the information about whether to heat up or not. This way, the room heat can be controlled and kept constant with a maximum of eight heat circuits and five HWT circuits. Among other things, this automatic feature ensures energy-saving heating operation. "Standalone operation" is also possible.



## Remote control via phone or tablet



### App for mobile boiler control

The Hargassner app allows you to control the boilers quickly and on the move and view information worldwide around the clock. The app immediately sends important information to the mobile end device via email or push message. This way, you know the status of the boiler at all times. (Requirements: Internet connection to the control unit on the boiler, smartphone with Android or iOS)



### Convenient remote controls

You want to change a setting on your boiler or see the current status – without going to your boiler room? No problem! The practical remote controls leave no operating wishes unfulfilled. They are simple, intuitive and boast a design that's perfectly tailored to your needs! Details of our analogue and digital (touch) remote controls can be found on our website [hargassner.com](http://hargassner.com)

## Smart home connections

"Smart home" is an innovative way of controlling the management of energy in your home according to your needs. Hargassner has a connection ready for the most common home automation systems (Loxone, KNX, Mod-Bus, etc.). The benefits are clear. You save energy and costs and enjoy comfort and safety at the same time.





## Simple **boiler operation**

Hargassner has control programmes for all boiler series; these programmes are all clearly arranged and easy to use. They provide a convenient way to control heat circuits and hot water.



### **Hargassner Lambda Touchtronic**

The software controls the Neo-HV, Neo-MHV and MV boiler series. The control unit controls two heat circuits and one hot water tank circuit as standard and can be extended as required. It is guided by weather conditions, so recognises changes in conditions as soon as they occur and seamlessly adjusts the boiler's output accordingly. As a result, the boiler is always running in the optimum output range, enabling you to save both fuel and unnecessary costs.



### **Hargassner Smart-Touch**

The Smart-HV boiler series is equipped with Hargassner's new Smart-Touch control unit. It includes the complete combustion control unit and a 3-sensor accumulator control unit. It is complemented by extra capacity for up to three mixed heat circuits and hot-water production, provided in the form of an additional board or a heat circuit module. An interface for combi operation with a Hargassner pellet boiler has also been integrated. This makes the new Smart-Touch control a perfectly tailored solution for the entire heating system.

## Lean back and relax – your heating system will do the rest!

### Control of heat circuits

The **Lambda Touchtronic** can control multiple heat circuits that are independent of each other. You can specify different settings in detail. For example, you can specify the room temperature you would like on a particular heat circuit at a particular time of day.



### Hot water tank

It's only necessary to set the desired hot water tank temperature and loading time. The control unit takes care of the rest. Hargassner guarantees hot water – 24 hours a day.



Another advantage is the automatic HWT priority. This ensures that the room temperature does not cool down during hot water tank loading periods.

Hargassner's **3G day/night reduction mode** makes it possible to set three outdoor temperature thresholds. One mode for "Heating during the day", one for "Reduction during the day" and one for "Reduction during the night". As a result, the boiler only operates if necessary – this is convenient for energy saving. Thanks to the clever residual heat use feature, the energy remaining in the boiler after it has been shut down is efficiently fed into the heat circuits.

**Your home therefore remains warm and cosy at all times.**

## Example of a day heating sequence with reduction logic

Fixed outdoor thresholds above which heating is required: Day from 16°C, night from -5°C (22:00 – 6:00 h)

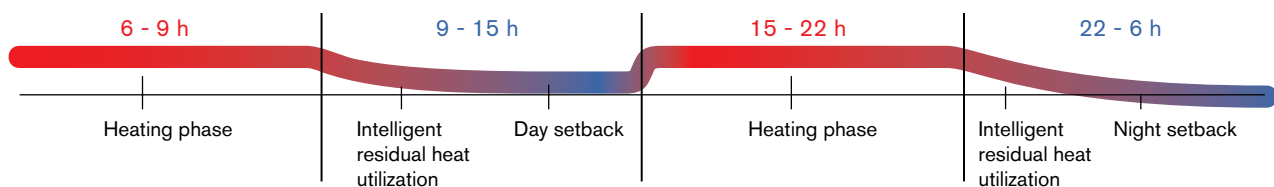

### Heating period 1

**06:00 – 09:00:** Outside it is -7°C, well below the defined threshold of +16°C. **The boiler switches on.**

### Day reduction period

**09:00 – 15:00:** Outside, the temperature rises to -1°C, which is below the day reduction threshold of +8°C. **The boiler switches on in day reduction mode.**

### Heating period 2

**15:00 – 22:00:** The outside temperature rises to +1°C, which is considerably lower than the threshold of +16°C. **The boiler remains on.**

### Night reduction period

**22:00 – 06:00:** The temperature cools down to -2°C, which is above the night reduction threshold of -5°C. **The boiler switches off.**



Permanently  
**storing heat**

## Accumulator systems for storing heat

By storing heat in an accumulator or domestic hot water tank, the boiler does not have to be in operation all the time and can therefore be operated efficiently. Depending on the model, either the heating water alone or heating and domestic water are stored.



### Universal heat storage tank – layered accumulator SP for 500–5,000 l

The layered accumulator SP and its solar variant can be used for all Hargassner boilers. The Hargassner partner installation company will be happy to recommend the right solution. The addition of a freshwater station to the models is planned. The heat energy is used efficiently thanks to an integrated return spread sheet and the variable sensor positioning. This saves heating costs in the long run.

- ✓ Optimised energy utilisation by a special spread sheet in the accumulator tank
- ✓ Efficient insulation with hard casing
- ✓ Suitable for **combination with solar**
- ✓ Easy and flexible installation, can be switched in parallel
- ✓ Very little space required
- ✓ Special accumulator sizes available on request



### Layered hygienic accumulator HSP – for 500–1,500 l

By means of the continuous flow principle and a built-in corrugated stainless steel pipe, this accumulator also enables domestic hot water to be heated. The generous size guarantees a high hot water output that is also safe from legionella. The HSP uses the heat energy particularly efficiently thanks to an integrated return spread sheet and variable sensor positioning. This heat storage tank is also available as a solar variant.

- ✓ Hygienic hot water production
- ✓ Optimised energy utilisation by a special spread sheet in the accumulator tank
- ✓ Efficient insulation with hard casing
- ✓ Suitable for **combination with solar**
- ✓ Easy and flexible installation, can be switched in parallel
- ✓ Very little space required
- ✓ Calcification protection through flexible stainless steel corrugated pipe



### Accumulator recommendations for boiler type

Which accumulator is suitable for which boiler (depending on the type of wood used):

Accumulator volume in litres	1000 2 x 500	1500 2 x 650	1500 2 x 825	2000 2 x 1000	2600 3 x 825	2 x 1500 3 x 1000	4000	2 x 2600	3 x 2000	3 x 2600
Smart-HV 17 - 23	Min.	Optimum	Min.	Optimum						
Neo-HV 20 - 30			Min.	Optimum	Min.	Optimum				
Neo-HV 40 - 60				Min.	Optimum	Min.	Optimum			
Neo-MHV 30 - 45							Min.	Optimum	Min.	Optimum

Accumulator dimensioning for winter operation and corresponding acceptance. During transitional periods and in summer, the boiler may only be partially filled. SP = layered accumulator, HSP = layered hygienic accumulator



**Sunny outlook**  
for the future



## Premium solar collectors



As an ideal complement to biomass heating systems, Hargassner offers high-quality solar panels for the preparation of heating and hot water. They are available as flat-plate collectors with high performance and a long lifetime, and they are available in reinforced versions for regions with high snow loads. The Hargassner Group also markets vacuum flat-plate collectors globally.

### Hargassner is the full-range supplier for biomass central heating systems.

Hydraulic components, accessories of all kinds are available extensively and in individual designs for all requirements. Precise coordination of the entire heating solution guarantees optimal cooperation of each individual component with each other. Additional information can be found in further product brochures or on [hargassner.com](http://hargassner.com) (also as download).



Find out more about our heating accessories at [hargassner.com](http://hargassner.com)

## Versatile heating components



### Substation, heat meters, fresh-water station & heat circuit groups

Expandable hydraulic components for heat circuit groups, freshwater preparation, etc. are adapted to the Hargassner boilers. Their control functions are taken over exactly by the Hargassner control system on the boiler.



### Stainless steel pipe flue connection set Ø 150 mm

At Hargassner you can also find special stainless steel flue pipe sets for wood log boilers. The connection sets include all the necessary components such as bows, pipes and boiler collars. There are two ADO versions of this set, one with an integrated chimney draught stabiliser (explosion protection) or one where the draught stabiliser for the chimney has to be provided by the customer.



### Back-end protection

This provides automatic back-end protection for Hargassner wood log boilers while simultaneously loading an accumulator tank. A fully insulated back-end protection group that includes a return mixer and highly efficient accumulator loading pump can be installed quickly and easily and reduces installation time and costs.



### OekoTube-Inside

The OekoTube-Inside is an electrostatic micro-dust separator recognised and eligible for funding by BAFA (Germany's Federal Office for Economic Affairs and Export Control) as an approved measure for reducing micro-dust levels. The filter is compatible with all Hargassner boilers up to 60 kW.

# TECHNICAL DATA

## SMART-HV 17 – 23

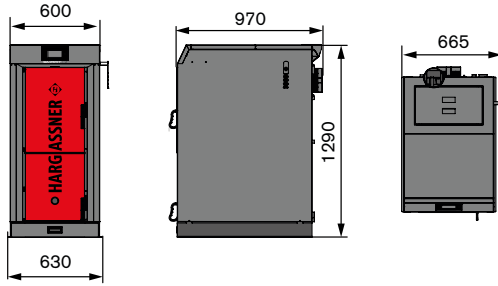

## Neo-HV 20 – 60

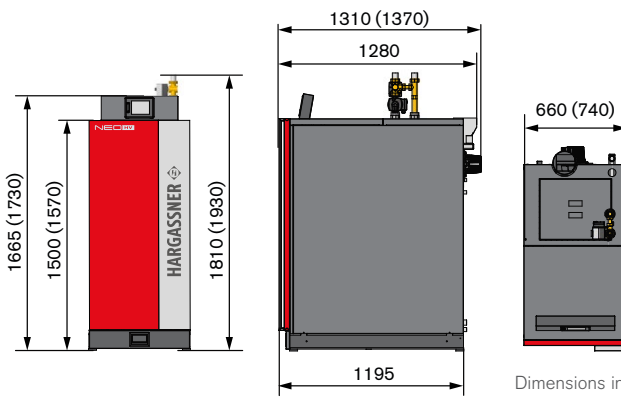

Top flue pipe connection.  
A rotatable exhaust fan housing for the left or right side is available as an option.

Dimensions in ( ) are for Neo-HV 40-60 boilers

Dimensions in ( ) are for Neo-HV 40-60 boilers

## Neo-MHV 30 – 45

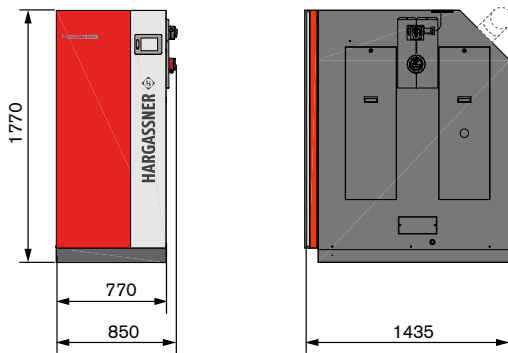

This product drawing is of a left-hand boiler (the boiler can be positioned with its left-hand side against the wall, and the door hinge and flue outlet are on the left).

## MV 55 – 80

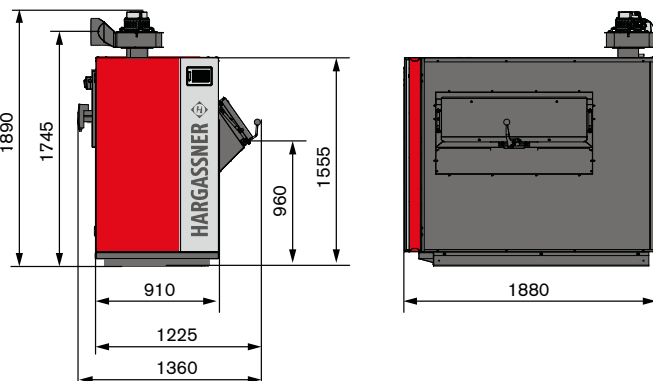

## MV 110

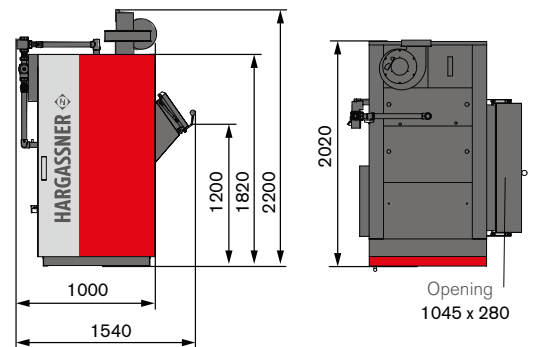

SMART-HV 17–23 wood gasifier ½ m					
	Unit	Smart-HV 17	Smart-HV 20	Smart-HV 23	
Power range	kW	17	15.1 – 19.4	15.1 – 23	
Efficiency Full load / Partial load	%	93.9	93.8 / 94.3	93.7 / 94.3	
Fuel heat output full load	kW	18.1	20.7	24.5	
Flue pipe diameter	mm		130		
Filling volume	Litre		102		
Filling room depth	mm		535		
Filling door H x B	mm		455 x 340		
Water content	Litre		72		
Water-side resistance ΔT 10 [K]	mbar	<1	<2	3	
Water-side resistance ΔT 20 [K]	mbar	<1	<1	<1	
Flow/Return	inches		6/4		
Weight	kg		400		
Size H / B / T	mm		1290 x 655 x 970		
Transport dimensions H / B / T	mm		1290 x 600 x 970		
Boiler label	Category	A+	A+	A+	
Composite label incl. the control unit	Category	A+	A+	A+	

Max. operation temperature 95°C, max. operating pressure 3 bar, electrical connection 230 V AC, 50 Hz, 13 A fuse  
A door hinged on the left is standard, but the door can be reversed on request (hinge can be changed to the right on-site)

Neo-HV 20 – 60 wood gasifier ½ m						
	Unit	Neo-HV 20	Neo-HV 30	Neo-HV 40	Neo-HV 50	Neo-HV 60
Power range	kW	12.7 – 25.4	15 – 30	20 – 40	24.5 – 49	30 – 60
Efficiency Full load / Partial load	%	93.7 / 92.8	92 / 92.8	92.3 / 93.7	92.5 / 94.4	92.8 / 95.4
Fuel heat output - full load	kW	27.1	32.6	43.3	53	64.7
Flue pipe diameter	mm			150		
Filling volume	Litre	166			222	
Filling room depth	mm			600		
Filling door H x B	mm			402 x 356		
Water content	Litre	137			166	
Water-side resistance ΔT 10 [K]	mbar	20.5	36	66.5	94	137
Water-side resistance ΔT 20 [K]	mbar	5.4	9.3	17.6	25	35
Flow/Return	inches			6/4 (1)		
Weight	kg	700			810	
Size H / B / T	mm	1665 x 660 x 1310			1730 x 740 x 1370	
Transport dimensions H / B / T	mm	1665 x 775 x 1450			1730 x 840 x 1450	
Boiler label	Category	A+	A+	A+	A+	A+
Composite label incl. the control unit	Category	A+	A+	A+	A+	A+

Max. operation temperature 95°C, max. operating pressure 3 bar, electrical connection 230 V AC, 50 Hz, 13 A fuse  
A door hinged on the left (without side shaft) is standard, but the door can be reversed on request (hinge can be changed to the right on-site)

Neo-MHV 30 – 45 wood gasifier ½ m & 1 m					
	Unit	Neo-MHV 30	Neo-MHV 35	Neo-MHV 40	Neo-MHV 45
Power range	kW	26.4 – 30	26.4 – 35	26.4 – 40	26.4 – 45
Efficiency Full load / Partial load	%	90.4 / 90.1	90.7 / 90.1	91 / 90.1	91.4 / 90.1
Fuel heat output full load	kW	33.2	38.6	44	49.1
Flue pipe diameter	mm			150	
Filling volume	Litre			300	
Filling room depth	mm			550 / 1080	
Filling door H x B	mm			755 x 502	
Water content	Litre			150	
Water-side resistance ΔT 10 [K]	mbar	25	33	43	55
Water-side resistance ΔT 20 [K]	mbar	6	9	11	14
Flow/Return	inches			5/4	
Weight	kg			1030	
Size H / B / T	mm			1770 x 850 x 1435	
Transport dimensions H / B / T	mm			1770 x 930 x 1630	
Boiler label	Category	A+	A+	A+	A+
Composite label incl. the control unit	Category	A+	A+	A+	A+

Max. operation temperature 95°C, max. operating pressure 3 bar, electrical connection 230 V AC, 50 Hz, 13 A fuse  
A door hinged on the left (without side shaft) is standard, but the door can be reversed on request (hinge can be changed to the right on-site)

MV 55 – 110 wood gasifier 1 m						
	Unit	MV 55	MV 60	MV 70	MV 80	MV 110
Power range	kW	49	60	70	80	115
Efficiency Full load / Partial load	%	91.0	92.0	93.0	94.0	91.0
Fuel heat output full load	kW	53.8	65.2	75.3	85.1	126.4
Flue pipe diameter	mm			200		250
Filling volume	Litre			450		720
Water content	Litre			250		300
Water-side resistance ΔT 10 [K]	mbar	78	113	151	195	85
Water-side resistance ΔT 20 [K]	mbar	23	32	42	54	22
Flow/Return	inches			2		
Weight	kg			1430		1860
Size H / B / T	mm			1555 x 910 x 1880		1820 x 1000 x 2020
Transport dimensions H / B / T	mm			1570 x 1100 x 1820		1820 x 1240 x 1830
Composite label incl. the control unit	Category	A+	A+	A+		-

Max. operation temperature 95°C, max. operating pressure 3 bar, electrical connection 230 V AC, 50 Hz, 13 A fuse  
A door hinged on the left (without side shaft) is standard, but the door can be reversed on request (hinge can be changed to the right on-site)  
Side shaft SR=right (front door hinge left), SL= left (front door hinge right)

# HARGASSNER

BIOMASS HEATING TECHNOLOGY



## Your expert for **PELLET** | **WOOD LOG** | **WOOD CHIP** BOILERS

Complete Hargassner range: pellet boilers, wood chip boilers, wood log boilers, accumulator tanks, industrial boilers up to 2.5 MW, heating modules, filling augers, combined heat power CHP, Power-Box warm-air module, solar panels and hydraulic accessories

Your specialist retailer

### AUSTRIA

**HARGASSNER Ges mbH**  
Anton Hargassner Strasse 1  
A-4952 Weng  
+43 77 23 52 74 - 0  
office@hargassner.at  
[hargassner.com](http://hargassner.com)

### GERMANY

**HARGASSNER DE GmbH**  
Heraklithstraße 10a  
D-84359 Simbach/Inn  
+49 85 71 93 997 - 0  
office@hargassner.com